

## Objective

Investigate why the expansion process of welded tubes (up to 24") resulted sometimes in a banana shape

## Research topics

- Quantify potential causes and solution methods
- Numerical modeling to evaluate the effect of design and process modifications

## Industrial benefits

- Modified equipment design with "first time right" success
- Eight systems sold of which one is installed on competitor's equipment
- Extra turnover > € 2.000.000

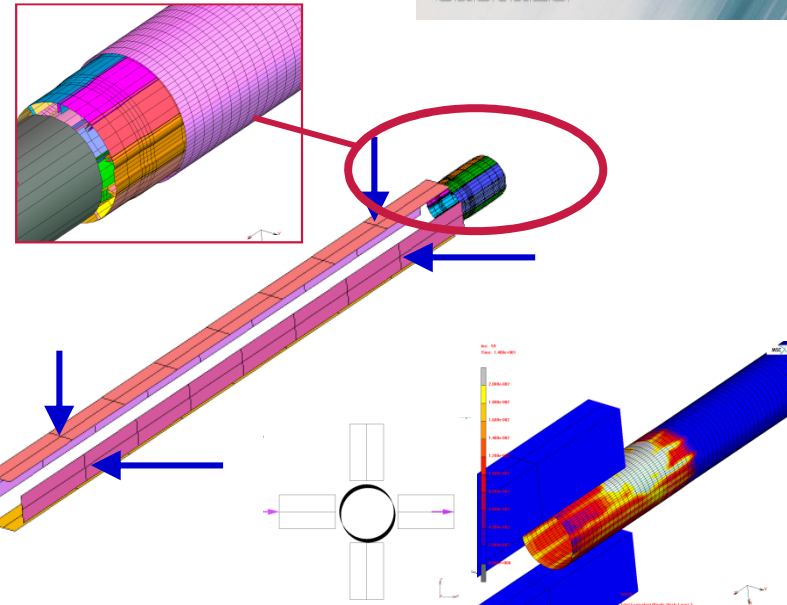
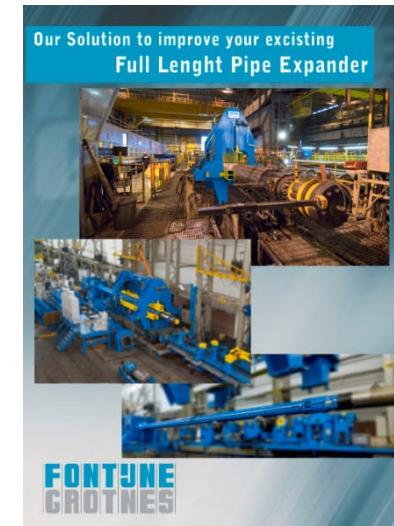

Full length pipe expander – Fontijne Grotnes